

**KWP non-clogging centrifugal pump**

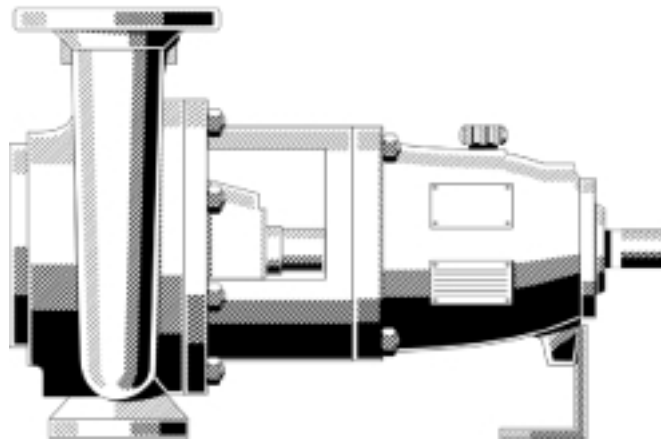

**Fields of Application**

For handling all kinds of pulps not liable to plait, as well as stock suspensions up to 5 % bone dry. This pump is used in the chemical and process engineering industries, paper and pulp industries, sugar, food and beverages industries, in flue gas desulphurisation and coal upgrading and in the treatment of industrial effluents.

**Design**

Horizontal, radially split volute casing pump in back pull-out design, with impeller adapted to meet application requirements, single-flow, single-stage.

**Special Features**

- Reinforced, axially adjustable bearing assembly on all pumps
- Shaft seal: mechanical seal integrated into the casing cover, or gland packing
- Even cast iron pumps are supplied with pump internals (impeller and wear plate) made of wear-resistant ERN (nickel cast iron)

**Designation**

Type series **KWP**  
 Impeller type **K**  
 Discharge nozzle DN **100**  
 Nominal impeller dia. **250**  
**KWP K 100 - 250**

Impeller types:  
 K = channel-type impeller  
 O = open multi-vane impeller  
 F = free-flow impeller

**Operating Data**

		Standard sizes	Supplementary sizes
Pump sizes	DN	40 up to 250	up to 800
Capacity	Q	up to 1300 m <sup>3</sup> /h	11000 m <sup>3</sup> /h
Head	H	up to 100 m	80 m
Operating pressure	p	up to 10 bar	
Operating temperature t			
	for H	from -10 to +120 °C	
	for GN, GH, GC <sub>2</sub>	from -10 to +200 °C	
	for C <sub>2</sub>	from -40 to +280 °C	

**Materials**

Part No.	Description	Material variant				
		GN	C <sub>2</sub>	GC <sub>2</sub>	H	GH
101	Pump casing	JL1040 <sup>1)</sup>	Noridur 1.4593	JL1040 <sup>1)</sup>	Norihard <sup>2)</sup>	JL1040 <sup>1)</sup>
135.01	Wear plate, suction side	ERN	Noridur 1.4593	ERN	Norihard	Norihard
162	Suction cover	JL1040 <sup>1)</sup>	Noridur 1.4593	JL1040 <sup>1)</sup>	Norihard	Norihard
163	Discharge cover	JL1040 <sup>1)</sup>	Noridur 1.4593	JL1040 <sup>1)</sup>	Norihard	Norihard
210	Shaft	C45+N	C45+N	C45+N	C45+N	C45+N
230	Impeller	ERN	Noridur 1.4593	Noridur 1.4593	Norihard	Norihard
330	Bearing bracket	JL1040 <sup>1)</sup>	JL1040 <sup>1)</sup>	JL1040 <sup>1)</sup>	JL1040 <sup>1)</sup>	JL1040 <sup>1)</sup>
344	Bearing bracket lantern	JL1040 <sup>1)</sup>	JL1040 <sup>1)</sup>	JL1040 <sup>1)</sup>	JL1040 <sup>1)</sup>	JL1040 <sup>1)</sup>
451.01	Stuffing box housing	-	Noridur 1.4593	JL1040 <sup>1)</sup>	JL1040 <sup>1)3)</sup>	JL1040 <sup>1)3)</sup>
524.01	Shaft protecting sleeve (packing)	1.4122 HV500	1.4539	1.4122 HV500	1.4122 HV500	1.4122 HV500
524.01	Shaft protecting sleeve (mech. seal)	1.4539	1.4539	1.4539	1.4539	1.4539
906	Impeller screw	C22+N	Noridur 1.4593	C22+N	C22+N	C22+N

1) GJL-250 to EN 1561  
 2) without auxiliary connection holes (pressure gauge connection and casing drain)  
 3) together with NORIHARD discharge cover



### Selection Charts KWP

n = 2900 1/min

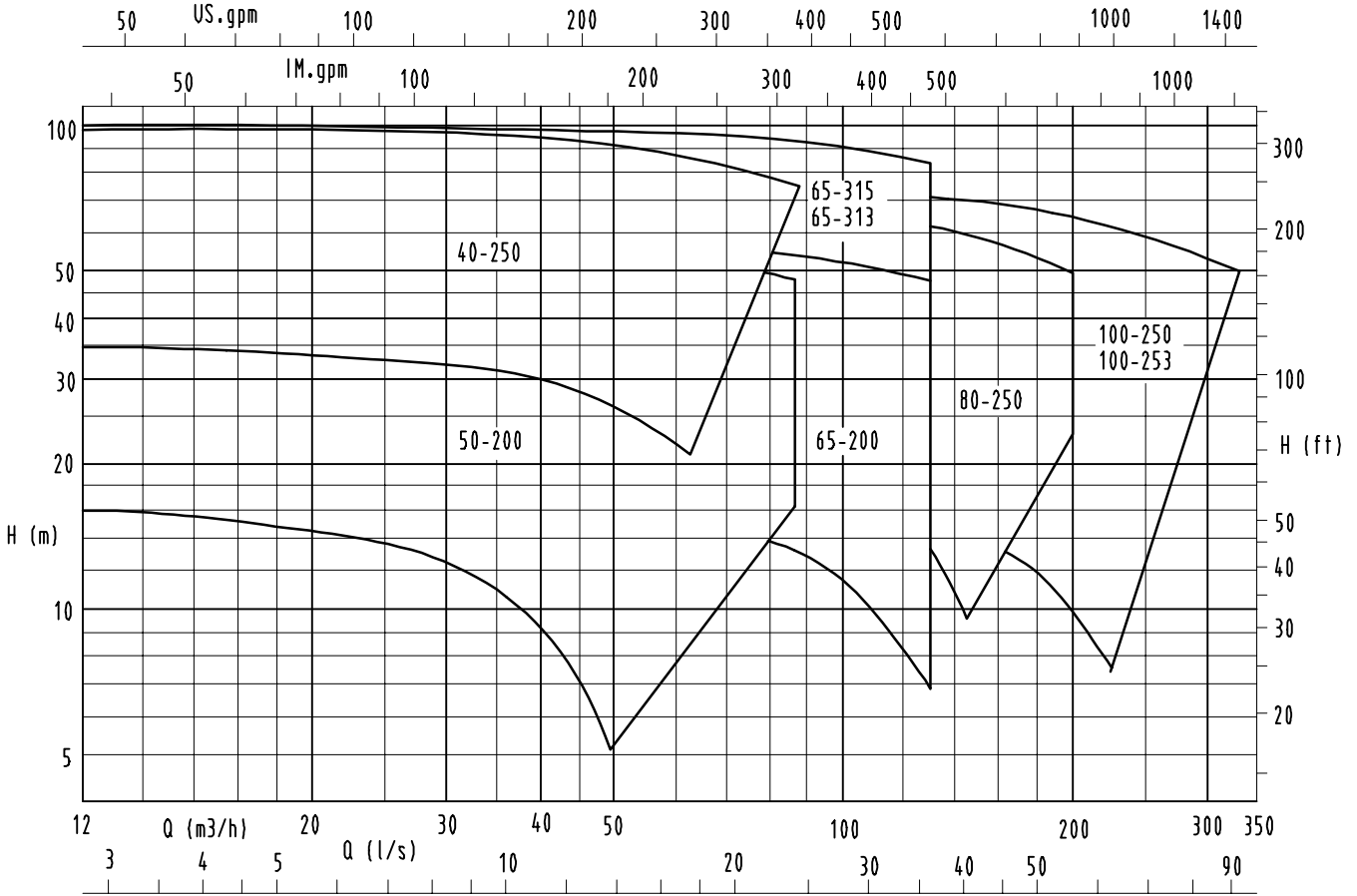

2361.4052/10B

n = 1450 1/min

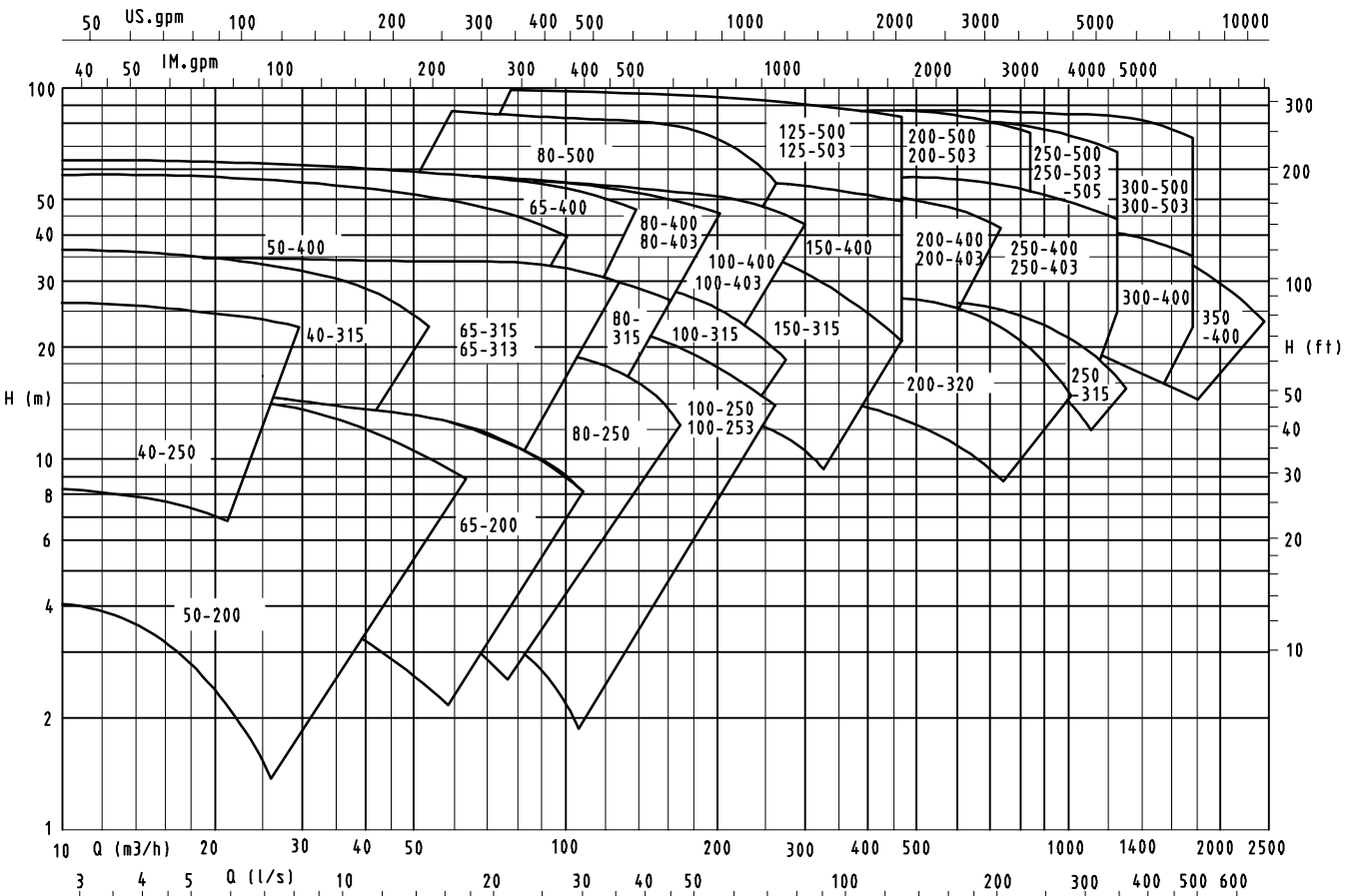

2361.4054/15B

**Selection Charts KWP**

n = 960 1/min

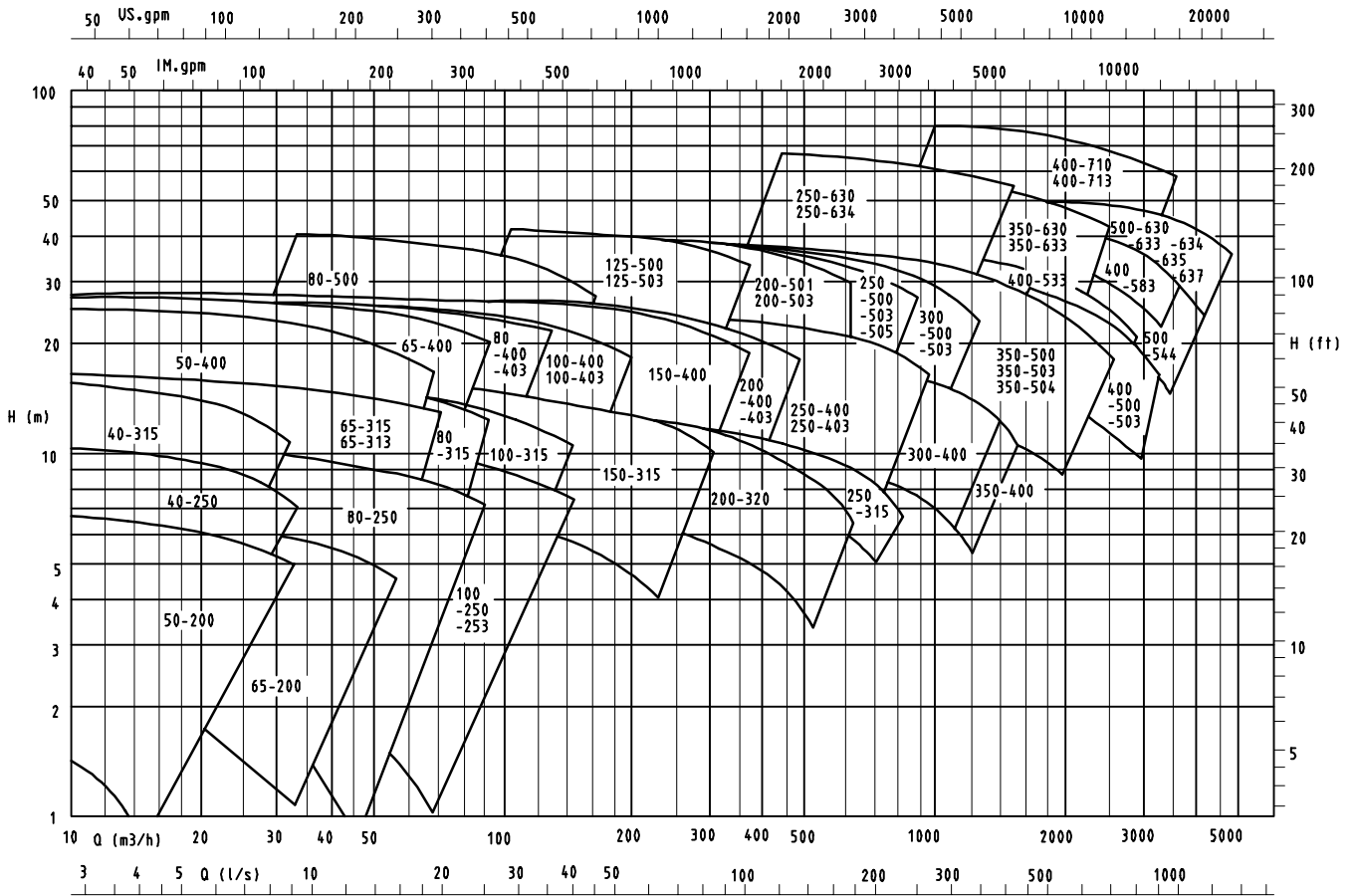

2361.4056/15B

n = 580 1/min

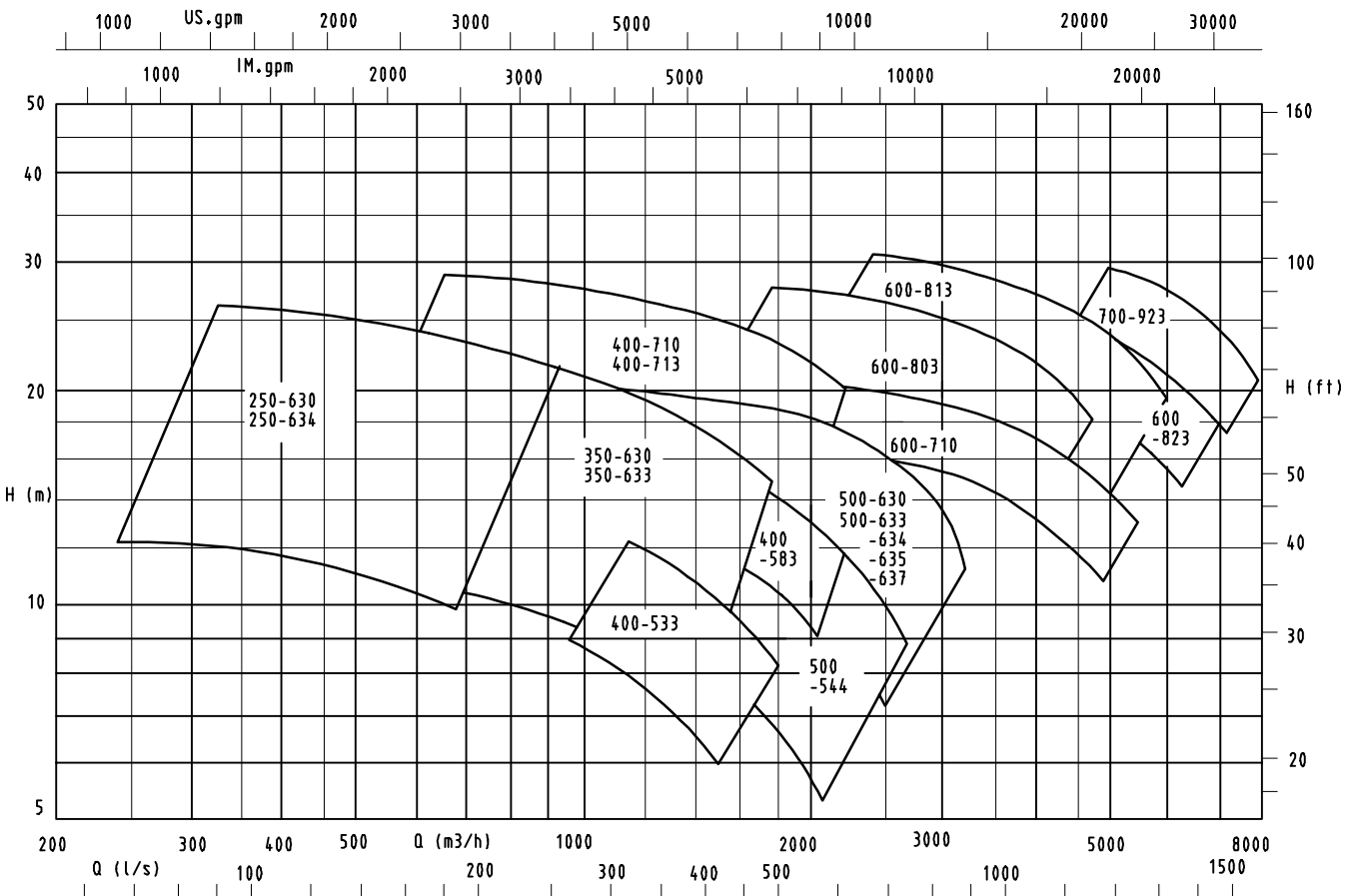

2361.4510/3B

## Design Features

Flange design in accordance with DIN/EN up to PN 16; other flange designs are possible.

Shaft not in contact with the medium handled (dry shaft); therefore no special materials required.

Back vanes for reduced axial thrust and shaft seal balancing.

All mechanical seals integrated in the casing cover with conical seal chamber (A-type cover), therefore improved internal circulation, automatic venting and dead-end operation possible.

Rotor and bearings are dimensioned for a shaft deflection at the shaft seal below 0.05 mm and a bearing life of more than 17 500 operating hours.

On request, pump casing is available with inspection hole.

Safe design of all pressure-retaining components due to quality casting with corrosion/wear allowance.

High efficiencies in the case of channel-type impeller design; impeller with front vanes and diagonal gap.

Pump casing with suction-side wear plate in wear-resistant diagonal gap design.

Due to the back pull-out design, the casing may remain in the pipeline when the pump is dismantled.

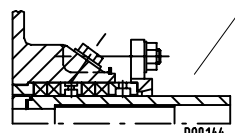

Pump version with gland packing and special discharge cover.

Jacking screws facilitate dismantling.

Use of existing modular design components ensures small stock of spare parts and fast delivery.

Cylindrical roller bearing as movable bearing permits easy assembly and compensates possible thermal expansion of the shaft.

Constant-level oiler ensures constant lubrication of the bearings.

Reinforced adjustable bearing assembly.

Rigid and stable support foot ensures that even in the case of high external forces the shaft is only slightly displaced in the coupling area.

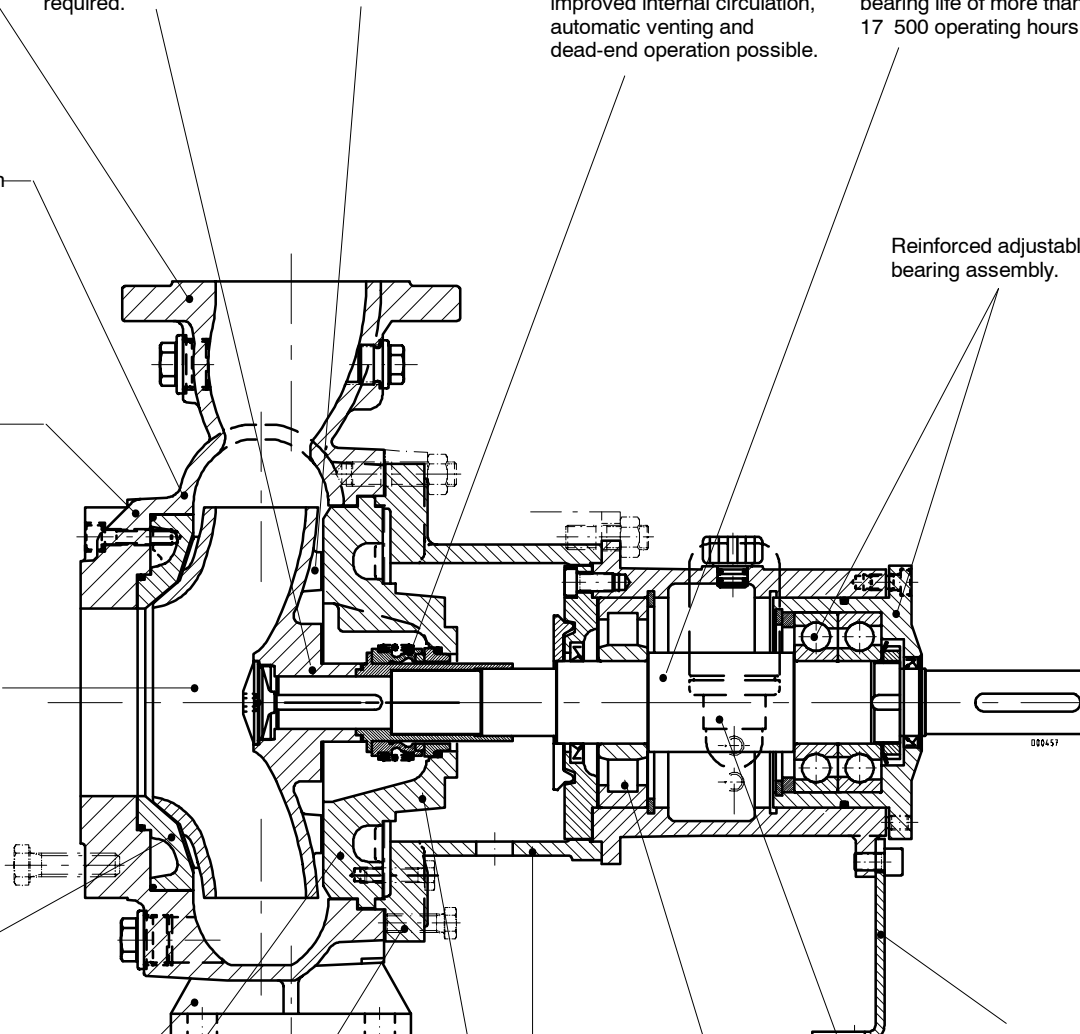

**Technical Data**  
**Standard Pump Sizes**

		Unit	Pump sizes																															
			P03ax							P04ax							P05ax							P06x										
			40-250	50-200	50-201	65-200	65-201	80-250	80-251	40-315	50-400	65-315	65-313	65-400	80-311	80-315	100-250	100-251	100-253	100-315	80-400	80-403	100-400	100-403	150-311	150-315	150-400	200-320	80-500	125-500	125-503	200-400	200-403	250-315
Bearing bracket			P03ax							P04ax							P05ax							P06x										
Impeller K	Impeller outlet width	mm	15	34	-	46	-	50	-	15	15	42	15	34	-	44	60	-	28	54	46	15	50	20	-	88	64	88	20	50	21	80	40	103
	Max. impeller dia.	mm	260	209	-	209	-	260	-	320	408	320	320	408	-	320	260	-	260	320	404	404	404	404	-	320	404	320	504	504	509	403	404	324
	Min. impeller dia.	mm	170	120	-	145	-	170	-	230	330	230	230	330	-	260	180	-	180	230	280	280	280	280	-	260	320	257	380	350	350	320	320	285
Impeller O	Impeller outlet width	mm	-	30	-	30	-	36	-	-	-	25	-	-	-	50	-	-	-	28	-	35	-	-	65	-	-	-	-	-	-	78	-	-
	Max. impeller dia.	mm	-	209	-	209	-	260	-	-	-	320	-	-	-	260	-	-	-	404	-	404	-	-	320	-	-	-	-	-	-	404	-	-
	Min. impeller dia.	mm	-	160	-	160	-	170	-	-	-	230	-	-	-	180	-	-	-	280	-	280	-	-	260	-	-	-	-	-	-	320	-	-
Impeller F	Free impeller passage	mm	-	-	45	-	55	-	60	-	-	-	-	50	-	-	70	-	-	-	-	-	-	90	-	-	-	-	-	-	-	-	-	
	Max. impeller dia.	mm	-	-	209	-	209	-	260	-	-	-	-	320	-	-	260	-	-	-	-	-	-	-	320	-	-	-	-	-	-	-	-	-
	Min. impeller dia.	mm	-	-	130	-	145	-	170	-	-	-	-	260	-	-	180	-	-	-	-	-	-	-	260	-	-	-	-	-	-	-	-	-
Shaft dia.	in stuffing box housing	mm	33							42							53							65										
	at bearings	pump side	45							55							65							65										
		motor side	45							55							65							65										
	at coupling	mm	32							42							48							60										
Shaft protect. sleeve	Packing	mm	45							55							70							80										
	Mechanical seal	mm	depending on make																															
Bearings	pump side		NU 409							NU 411							NU 413							NU 413										
	motor side		2 x 7309 BG							2 x 7311 BG							2 x 7313 BG							2 x 7313 BG										
Gland	Bore dia.	mm	65							75							95							95										
	Length	mm	64							64							79							79										
	Packing ring dimensions	mm	10 x 10							10 x 10							12,5 x 12,5							12,5 x 12,5										
	Number of packing rings	pcs.	4							4							4							4										
	Lantern ring width	mm	20							20							25							25										
	Clearance for removal	mm	80							65							75							75										
Pressure limits	Max. operating pressure	bar	see operating data																															
	Max. test pressure	bar	1.5 times the max. admissible operating pressure, min. 6 bar																															
Temp. limits	Max. temperature of medium handled	°C	see operating data																															
Drive	P/n value (shaft C 45 N)		0.03							0.067							0.144							0.235										

		Unit	Pump sizes																																			
			200-500	200-501	200-503	250-400	250-403	250-500	250-503	250-505	250-630	250-634	300-400	300-500	300-503	350-400	350-500	350-503	350-504	350-630	350-633	400-500	400-503	400-533	400-583	400-710	400-713	500-544	500-630	500-633	500-634	500-635	500-637	600-710	600-803	600-813	600-823	620-923
Bearing bracket			P 08sx / P 10ax / P 12sx														P 10ax / P 12sx / P 16ax										P 16ax / P 20sx											
Impeller K	Impeller outlet width	mm	75	75	40	107	75	85	50	70	107	70	100	110	100	130	145	95	72	140	90	155	155	105	120	162	115	144	142	123	85	75	123	210	135	144	187	210
	Max. impeller dia.	mm	504	504	504	409	409	504	504	504	630	630	409	504	504	408	508	508	507	630	630	508	508	538	600	730	730	590	636	636	636	636	636	736	780	830	800	870
	Min. impeller dia.	mm	400	400	400	338	340	400	400	436	500	480	320	400	420	330	390	472	460	500	500	430	445	496	550	630	630	495	528	534	554	565	540	664	718	710	731	800
Shaft dia.	in stuffing box housing	mm	P 08sx: 80; P 10ax: 100; P 12sx: 120; P 16ax: 158; P 20sx: 198																																			
	at bearings	pump side	P 08sx: 80; P 10ax: 120; P 12sx: 120; P 16ax: 160; P 20sx: 200																																			
		motor side	P 08sx: 95; P 10ax: 120; P 12sx: 120; P 16ax: 160/140; P 20sx: 200/190																																			
	at coupling	mm	P 08sx: 75; P 10ax: 95; P 12sx: 110; P 16ax: 120; P 20sx: 145																																			
Shaft protect. sleeve	Packing	mm	P 08sx: 100; P 10ax: 120; P 12sx: 140; P 16ax: 170; P 20sx: 1)																																			
	Mechanical seal	mm	depending on make																																			
Bearings	pump side		P 08sx: NU 416; P 10ax: NU 324; P 12sx: NU 324; P 16ax: NU 232; P 20sx: NU 240																																			
	motor side		P 08sx: 2 x 7319 BG; P 10ax: 2 x 7324 BG; P 12sx: 2 x 7324 BG; P 16ax: NU 232/QJ 328; P 20sx: 29340/NU 238																																			
Gland	Bore dia.	mm	P 08sx: 103; P 10ax: 103; P 12sx: 103; P 16ax: 130; P 20sx: 1)																																			
	Length	mm	P 08sx: 132; P 10ax: 152; P 12sx: 172; P 16ax: 210; P 20sx: 1)																																			
	Packing ring dimensions	mm	P 08sx: 16 x 16; P 10ax: 16 x 16; P 12sx: 16 x 16; P 16ax: 20 x 20; P 20sx: 1)																																			
	Number of packing rings	pcs.	4																																			
	Lantern ring width	mm	P 08sx: 30; P 10ax: 30; P 12sx: 30; P 16ax: 25; P 20sx: 1)																																			
	Clearance for removal	mm	P 08sx: 105; P 10ax: 105; P 12sx: 105; P 16ax: 25; P 20sx: 1)														P 10ax: 30; P 12sx: 30; P 16ax: 25				P 16ax: 25; P 20sx: 1)																	
Pressure limits	Max. operating pressure	bar	see operating data																																			
	Max. test pressure	bar	1.5 times the max. admissible operating pressure, min. 6 bar																																			
Temp. limits	Max. temperature of medium handled	°C	see operating data																																			
Drive	P/n value (shaft C 45 N)		P 08sx: 0.458; P 10ax: 0.91; P 12sx: 1.75; P 16ax: 2.0; P 20sx: 1)																																			

1) Data on request.

## Pump Sizes

Dis-charge nozzle	Nominal impeller dia.																					
	200/201			250/251/253			315/311 313/320			400/403		500/501/ 503 504/505		544	583	630/633 634/635 637		710/ 713	803	813	823	923
	Impeller type																					
	K	F	O	K	F	O	K	F	O	K	O	K	K	K	K	K	K	K	K	K	K	K
40				x			x					x										
50	x	x	x									x										
65	x	x										x										
80				x	x	x	x	x				x	x									
100				x	x	x	x					x	x		x							
125												x										
150												x	x									
200												x	x	x								
250												x	x									
300												x	x									
350												x										
400																						
500																x						
600																			x			
700																				x		
																						x

## Flanges

Suction flanges up to DN 350 are supplied with pocket holes for hex. head bolts to DIN 2501, PN 10/16; suction flanges DN 400 and above with through-holes to EN 1092-2, PN10.

The discharge flange of sizes DN 40 to 150 is supplied in acc. with EN 1092-2, PN 16 (with through-holes), sizes DN 200 and above are supplied with flanges acc. to EN 1092-2, PN 10.

## Casing

Radially split, consisting of pump casing with integrally cast suction and discharge nozzle as well as discharge cover. The discharge cover is available with integrally cast stuffing box housing or with bolted coolable stuffing box housing. The pump casing is available with or without wear plate. From pump size 400-710 onwards the suction nozzle is integrally cast on a separate suction cover.

### Gland packing:

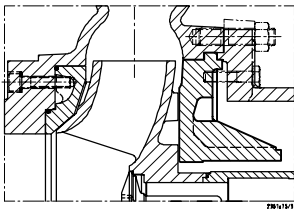

Discharge cover with integrally cast stuffing box housing (casing design 2)  
Material variants: GN, GC<sub>2</sub>, C<sub>2</sub>

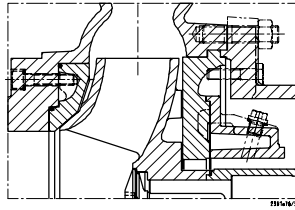

Discharge cover with bolted coolable stuffing box housing (casing design 3)  
Material variants: GH, H

### Mechanical seal:

Discharge cover with conical seal chamber (A-type cover)  
Material variants: GN, GC<sub>2</sub>, C<sub>2</sub>, GH, H

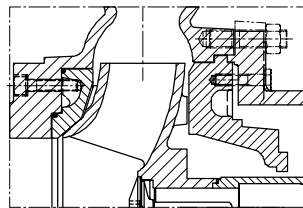

## Shaft Seal

Single-acting mechanical seal in conical seal chamber, therefore improved internal circulation; automatic venting and dead-end operation possible.

Gland packing variant available with barrier liquid /flushing liquid connection.

## Gland packing

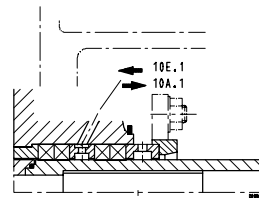

Standard version

### Mechanical seal

"A" version (without spring-loaded ring cover), no external flushing required

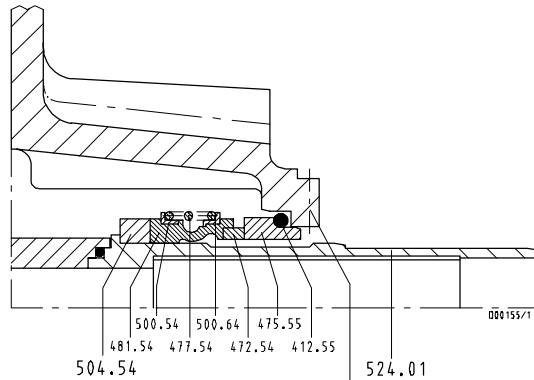

single-acting, unbalanced

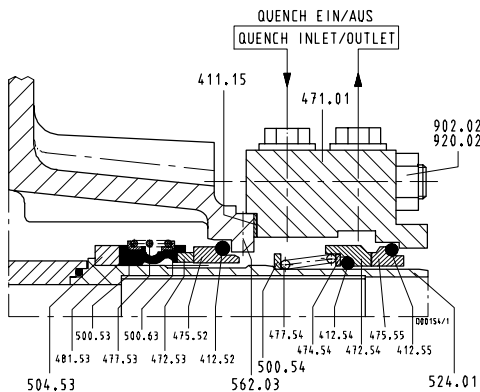

single-acting, unbalanced version with quench feed and additional single-acting mechanical seal (tandem arrangement)

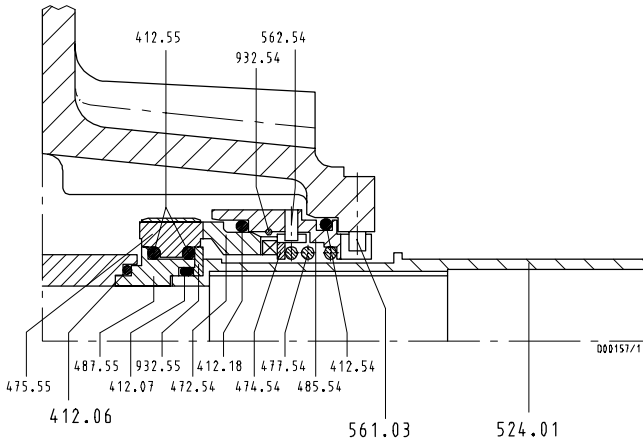

single-acting, balanced, stationary

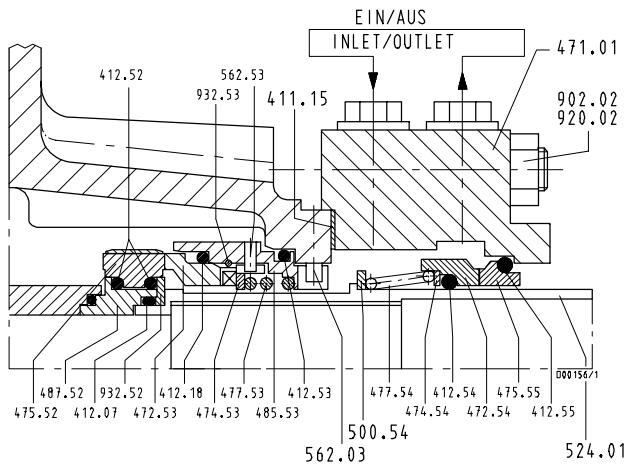

single-acting, balanced, stationary version with quench feed and additional single-acting mechanical seal (tandem arrangement)

### Acceptance Tests / Guarantees

Each pump is subjected to a functional test, and its duty point is guaranteed according to DIN 1944/III.

The following acceptance tests may be performed and certified at extra charge:

Performance test DIN 1944/III / ISO 2548 C:

1 measuring point / 5 measuring points

Performance test DIN 1944/II / ISO 3555 B:

5 measuring points (refer to individual performance curve)

NPSH test 1 measuring point / 5 measuring points

If  $Q < 0.3 Q_{opt}$ , measuring the NPSH value is difficult, and the NPSH value cannot be certified. The value given in the individual performance curves can be fully used, however.

### Coating and Preservation

acc. to KSB standard AN 1865

KWP (GN, GH, GC<sub>2</sub>, H)

R 1 1 1 W

KWP (C<sub>2</sub>)

N 0 1 1 U

Treatment of unmachined parts

Coating - wetted parts

Coating - baseplate and bearing bracket

Coating - motor

Preservation

N = reaction primer, wetted parts without last coating (internal and external)

R = reaction primer

1 = synthetic enamel RAL 5002, ultramarine blue

0 = without top coat

W = rinsed with water repellent, bright parts made of materials liable to rust with protective coating

U = untreated, bright parts made of materials liable to rust with protective coating

### Recommended Spare Parts Stock for 2 Years' Operation

Part No.	Description	Number of pumps (including stand-by pumps)							
		2	3	4	5	6	8	10 and more	
135.01	Wear plate, suction side	2	2	2	3	3	4	50 %	
210	Shaft with small parts	1	1	1	2	2	2	20 %	
230	Impeller	1	1	1	2	2	2	20 %	
320/321	Rolling element bearings (set)	1	1	2	2	2	3	25 %	
330	Bearing bracket, complete	-	-	-	-	-	1	2 pieces	
433 1)	Spring-loaded ring	2	3	4	5	6	7	90 %	
	Seat ring	2	3	4	5	6	7	90 %	
	Secondary seal rings	2	3	4	5	7	9	100 %	
	Spring	1	1	1	1	2	2	20 %	
456 1)	Neck bush	1	1	2	2	2	3	30 %	
458 1)	Lantern ring	1	1	2	2	2	3	30 %	
	Set of gaskets or O-rings	4	6	8	8	9	12	150 %	
461 1)	Gland packing (4 rings)	4	4	6	6	6	8	100 %	
524	Shaft protecting sleeve	2	2	2	3	3	4	50 %	

1) if fitted



## Dimensions

Pump sizes on bearing brackets P03x to P06x

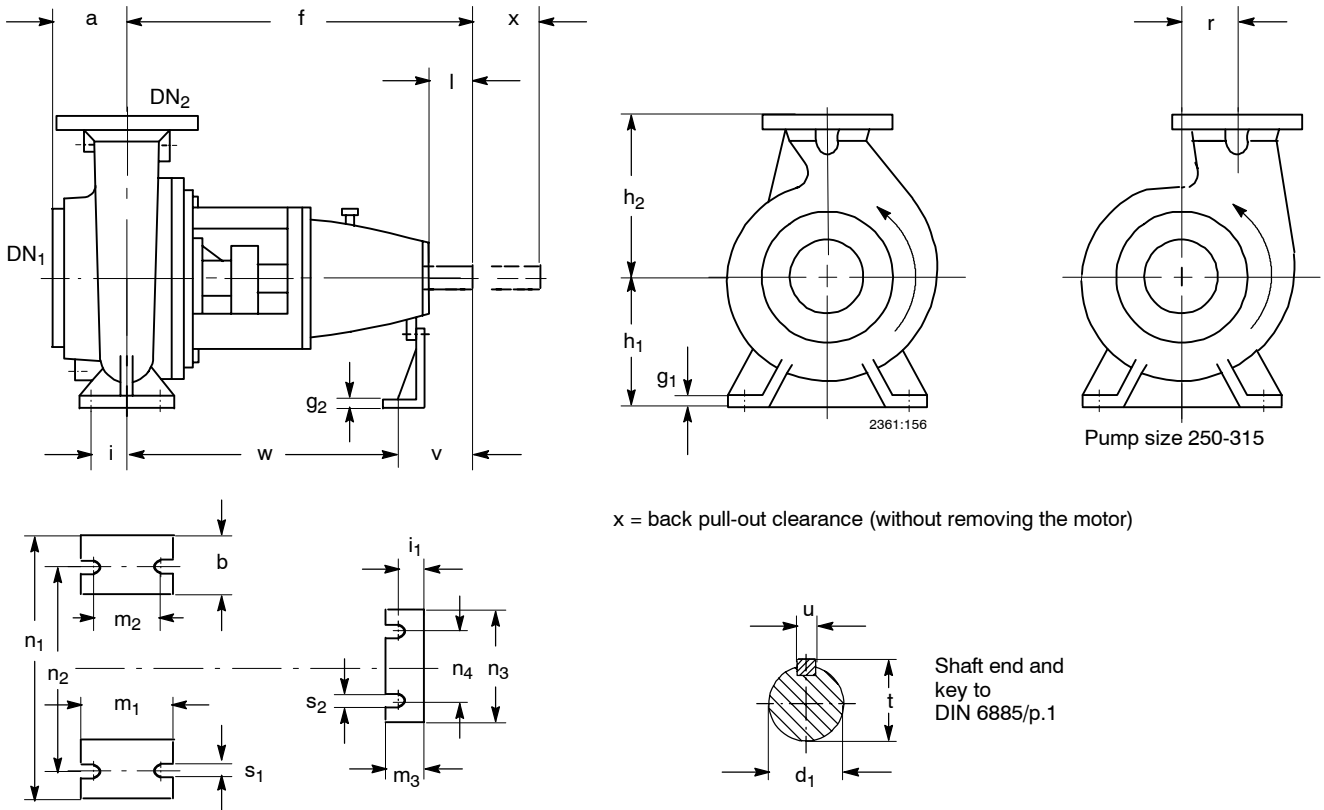

Pump size	Bearing bracket	Pump dimensions																Shaft end					Foot dimensions							
		DN <sub>1</sub>	DN <sub>2</sub>	a	b	f	g <sub>1</sub>	g <sub>2</sub>	h <sub>1</sub>	h <sub>2</sub>	m <sub>1</sub>	m <sub>3</sub>	n <sub>1</sub>	n <sub>3</sub>	r	d	l	t	u	x	i	i <sub>1</sub>	m <sub>2</sub>	n <sub>2</sub>	n <sub>4</sub>	s <sub>1</sub>	s <sub>2</sub>	v	w	
40-250 40-315	P 03ax P 04ax	65 80	40 40	100 125	65 80	500 530	16 18	4 6	180 225	225 250	125 160	48 48	320 400	160 160	-	32 42	80 110	35,3 45,1	10 12	100 140	47,5 60	30 33	95 120	250 315	110 110	16 18	14 14	130 160	370 370	
50-200,201 50-400	P 03ax P 04ax	65 80	50 50	112 120	50 80	500 530	14 18	4 6	160 280	200 325	100 160	48 48	265 435	160 160	-	32 42	80 110	35,3 45,1	10 12	100 140	35 60	30 33	70 120	212 355	110 110	14 19	14 14	130 160	370 370	
65-200,201 65-315,311,313 65-400	P 03ax P 04ax P 04ax	80 80 80	65 65 65	125 140 140	65 80 80	500 530 530	16 18 18	4 6 6	180 225 280	225 280 355	125 160 160	48 48 48	320 400 435	160 160 160	-	32 42 42	80 110 110	35,3 45,1 45,1	10 12 12	100 120 120	47,5 60 60	30 33 33	95 120 120	250 315 315	110 110 110	14 18 18	14 14 14	130 160 160	370 370 370	
80-250,251 80-315,311 80-400,403 80-500	P 03ax P 04ax P 05ax P 06x	100 100 100 125	80 80 80 80	125 140 140 140	80 80 80 100	500 530 670 720	18 18 18 24	6 6 12 12	225 280 355 450	280 315 355 450	160 180 160 200	48 48 60 60	400 400 435 550	160 160 200 200	-	32 42 48 60	80 110 110 140	35,3 45,1 51,5 64,2	10 12 14 18	100 120 160 160	60 60 75 75	30 33 39 39	120 120 150 150	315 315 450 450	110 110 140 140	18 19 23 23	14 14 18 18	130 160 170 205	370 370 500 515	
100-250,251,253 100-315 100-400,403	P 04ax P 04ax P 05ax	125 125 125	100 100 100	140 140 140	80 80 100	530 530 670	18 18 20	6 6 12	225 250 280	280 315 355	160 180 200	48 48 60	400 400 500	160 160 200	-	42 42 48	110 110 110	45,1 45,1 51,5	12 12 14	140 140 160	60 60 75	33 33 39	120 120 150	315 315 400	110 110 140	18 18 23	14 14 18	160 160 170	370 370 500	
125-500,503	P 06x	150	125	160	100	720	24	12	355	450	200	60	550	200	-	60	140	64,2	18	160	75	39	150	450	140	23	18	205	515	
150-315,311 150-400	P 05ax P 05ax	150 150	150 150	180 160	100 100	670 670	22 22	12 12	315 315	400 450	200 200	60 60	550 550	200 200	-	48 48	110 110	51,5 51,5	14 14	160 160	75 75	39 39	150 150	450 450	140 140	23 23	18 18	170 170	500 500	
200-320 200-400,403	P 05ax P 06x	200 200	200 200	200 180	100 100	697 720	22 24	12 12	355 500	450 500	200 200	60 60	550 550	200 200	-	48 60	110 140	51,5 64,2	14 18	160 160	75 75	39 39	150 150	450 450	140 140	22 23	18 18	170 205	527 515	
250-315	P 06x	250	250	215	130	720	26	12	500	400	260	60	800	200	315	60	140	64,2	18	160	95	39	190	670	140	26	18	205	515	

## Dimensions

Pump sizes on bearing brackets P08sx to P20sx

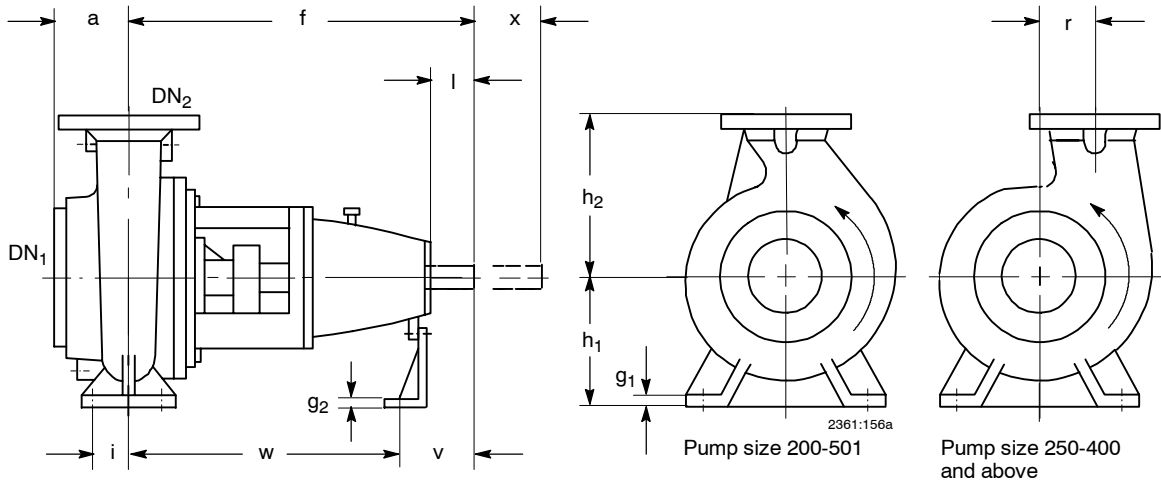

x = Back pull-out clearance (without removing the motor)

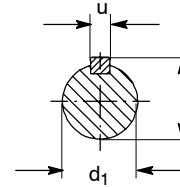
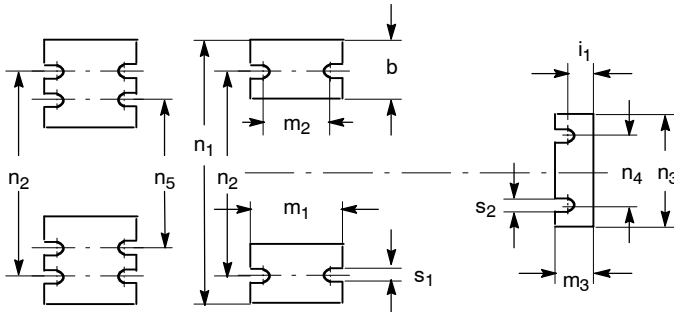

Shaft end and key to  
DIN 6885/p.1

Pump size	Bearing bracket	Pump dimensions														Foot dimensions							
		DN <sub>1</sub>	DN <sub>2</sub>	a	b	g <sub>1</sub>	g <sub>2</sub>	h <sub>1</sub>	h <sub>2</sub>	m <sub>1</sub>	m <sub>3</sub>	n <sub>1</sub>	n <sub>3</sub>	r	x	i	i <sub>1</sub>	m <sub>2</sub>	n <sub>2</sub>	n <sub>4</sub>	n <sub>5</sub>	s <sub>1</sub>	s <sub>2</sub>
200-500,501,503	P08sx/10ax/12sx	200	200	200	120	24	12	375	560	200	60	700	200	-	250	75	39	150	560	140	-	23	18
250-400,403	P08sx/10ax	250	250	180	130	26	12	425	375	260	60	800	200	300	315	95	39	190	670	140	-	26	18
250-500,503,505	P08sx/10ax/12sx	250	250	200	130	26	12	425	400	260	60	800	200	315	315	95	39	190	670	140	-	28	18
250-630,634	P08sx/10ax/12sx	250	250	200	150	32	12	500	450	260	60	900	200	400	315	95	39	190	750	140	-	26	18
300-400	P08sx/10ax	300	300	180	180	32	12	500	400	360	60	900	200	390	315	125	39	250	750	140	-	28	18
300-500,503	P08sx/10ax/12sx	300	300	200	130	26	12	450	450	260	60	800	200	315	315	95	39	190	670	140	-	28	18
350-400	P08sx/10ax	350	350	200	225	32	12	560	450	400	60	1080	200	395	315	150	39	300	1000	140	750	28	18
350-500,503,504	P08sx/10ax/12sx	350	350	290	225	32	12	560	500	400	60	1080	200	415	315	150	39	300	1000	140	750	28	18
350-630,633	P08sx/10ax/12sx	350	350	250	150	32	12	560	560	360	60	900	200	400	350	125	39	250	750	140	-	28	18
400-500,503	P08sx/10ax/12sx	400	400	260	250	40	16	670	500	400	85	1150	216	490	400	150	59	300	1040	140	800	39	18
400-533	P10ax/12sx	400	400	350	250	40	16	630	525	360	85	1150	216	475	400	125	50	250	1040	140	800	40	18
400-583	P10ax/12sx	400	400	390	250	40	16	700	540	400	85	1150	216	510	400	150	50	300	1040	140	800	40	18
400-710,713	P10ax/12sx/16ax	500	400	350	250	40	16	670	600	400	85	1150	216	480	350	150	59	300	1040	140	800	38	18
500-544	P10ax/12sx	500	500	425	250	40	30	800	630	400	125	1400	200	585	450	150	60	300	1290	140	1050	38	18
500-630,633,634	P10ax/12sx/16ax	500	500	375	250	40	16	750	630	400	85	1400	216	575	400	150	50	300	1290	140	1050	38	18
500-635,637	P10ax/12sx/16ax	500	500	375	250	40	16	750	630	400	85	1400	216	575	400	150	50	300	1290	140	1050	38	18
600-710	P12sx/16ax	600	600	500	250	40	18	900	750	400	80	1600	216	680	500	150	55	300	1490	140	1250	38	18
600-803,813,823	P 16ax/P 20sx 1)																						
700-923	P 20sx 1)																						

1) Dimensions on request

## Dimensions

Pump sizes on bearing brackets P08sx to P20sx

Pump size	Pump dimensions					Foot dimensions									
	f					v					w				
	P08sx	P10ax	P12sx	P16ax	P20sx	P08sx	P10ax	P12sx	P16ax	P20sx	P08sx	P10ax	P12sx	P16ax	P20sx
200-500,501,503	970	1160	1160	-	-	220	410	410	-	-	750	750	750	-	-
250-400,403	1000	1190	-	-	-	220	410	-	-	-	780	780	-	-	-
250-500,503,505	1000	1190	1190	-	-	220	410	410	-	-	780	780	780	-	-
250-630,634	1000	1190	1190	-	-	220	410	410	-	-	780	780	780	-	-
300-400	1000	1190	-	-	-	220	410	-	-	-	780	780	-	-	-
300-500,503	1000	1190	1190	-	-	220	410	410	-	-	780	780	780	-	-
350-400	1000	1190	-	-	-	220	410	-	-	-	780	780	-	-	-
350-500,503,504	1000	1190	1190	-	-	220	410	410	-	-	780	780	780	-	-
350-630,633	1000	1190	1190	-	-	220	410	410	-	-	780	780	780	-	-
400-500,503	1000	1190	1190	1)	-	220	410	410	1)	-	780	790	790	1)	-
400-533	-	1175	1175	1)	-	-	450	450	1)	-	-	725	725	1)	-
400-583	-	1180	1180	1)	-	-	450	450	1)	-	-	730	730	1)	-
400-710,713	-	1205	1205	1)	-	-	425	425	1)	-	-	780	780	1)	-
500-544	-	1190	1190	-	-	-	435	435	-	-	-	755	755	-	-
500-630,633,634	-	1190	1190	-	-	-	440	440	-	-	-	750	750	-	-
500-635,637	-	1190	1190	-	-	-	440	440	-	-	-	750	750	-	-
600-710	-	-	1240	1)	-	-	-	450	1)	-	-	-	790	1)	-
600-803,813,823	-	-	-	1)	1)	-	-	-	1)	1)	-	-	-	1)	1)
700-923	-	-	-	-	1)	-	-	-	-	1)	-	-	-	-	1)

1) On request

### Shaft end

Bearing bracket	d <sub>1</sub>	l	t	u
P 08sx	75	150	79,7	20
P 10ax	95	220	100,2	25
P 12sx	110	220	116,2	28
P 16ax	120	210	127,2	32
P 20sx	145	270	153	26

# General Drawing with List of Components

Pumps on bearing brackets P 03 ax to P 06 x

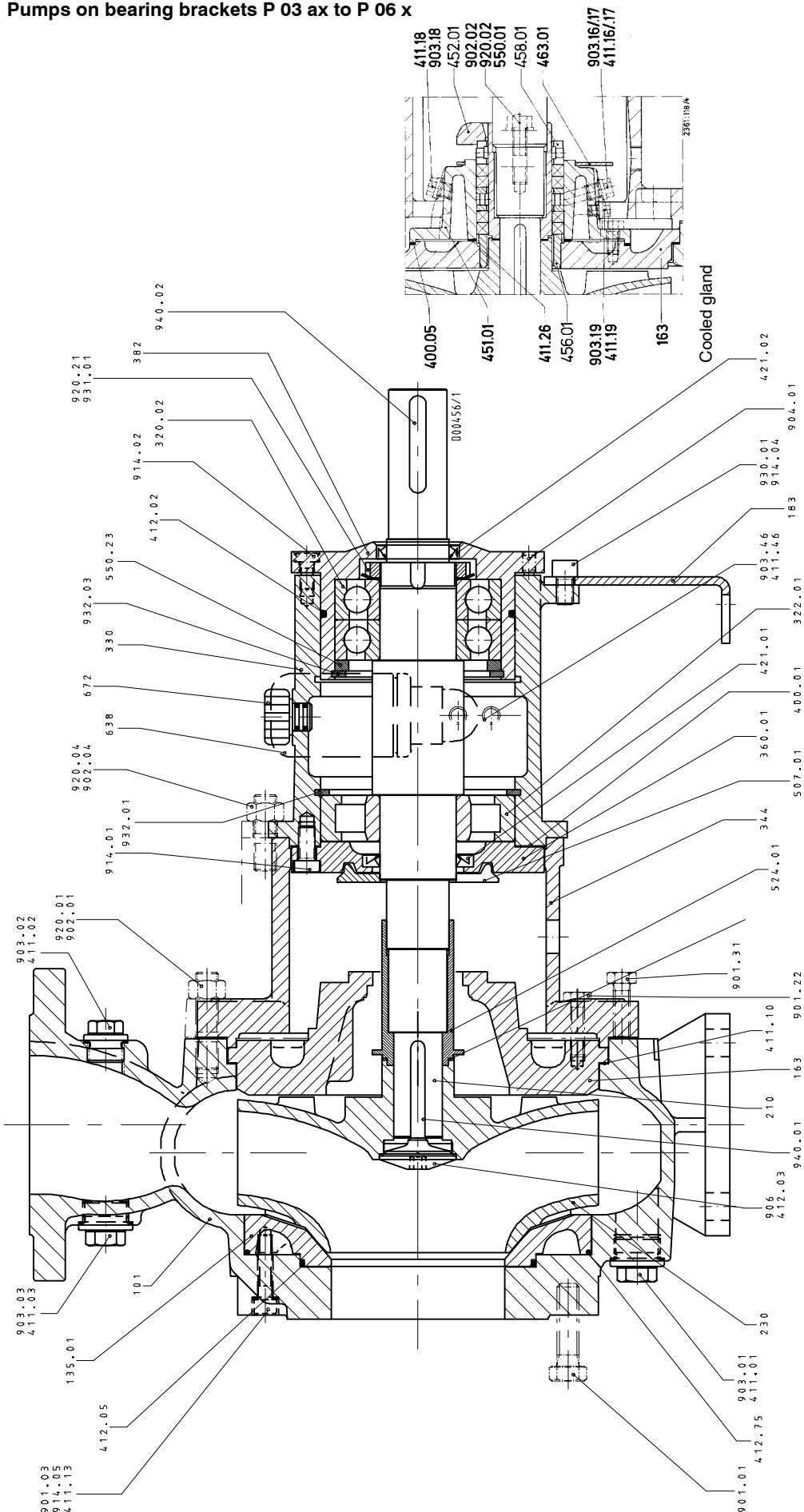

When ordering spare parts please always specify the type series/pump size, works No. (stamped on the name plate and on the suction nozzle flange), motor No. (serial No.), year of construction, quantity required, part No., description, material, medium handled, drawing no. and mode of dispatch.

Part No.	Description	Scope of supply
101	Pump casing	with joint ring 411.01 <sup>1)</sup> /.02 <sup>1)</sup> /.03 <sup>1)</sup> /.10, hex. head bolt 901.01, stud 902.01, screwed plug 903.01 <sup>1)</sup> /.02 <sup>1)</sup> /.03 <sup>1)</sup> , hex. nut 920.01
135.01 <sup>4)</sup>	Wear plate (suction-side)	with joint ring 411.13, O-ring 412.05/.75, hex. head bolt 901.03, socket head cap screw 914.05
163 <sup>2)</sup>	Discharge cover (A-cover)	with hex. head bolt 901.22
163 <sup>3)</sup>	Discharge cover (with integrally cast stuffing box housing)	with joint ring 411.16/.17, drip plate 463.01, disc 550.01, stud 902.02, screwed plug 903.16/.17, hex. nut 920.02
183	Support foot	with socket head cap screw 914.04, spring washer 930.01
210	Shaft	with keywayed nut 920.21, lockwasher 931.01, key 940.01/.02
230	Impeller	with O-ring 412.06
320.02	Angular contact ball bearing	
322.01	Cylindrical roller bearing	
330	Bearing bracket	
330	Bearing bracket (complete)	with bearing cover 360.01, bearing carrier 382, gasket 400.01, joint ring 411.46, O-ring 412.02, radial shaft seal ring 421.01/.02, support disc 550.23, constant-level oiler 638, vent plug 672, screwed plug 903.46, grub screw 904.01, socket head cap screw 914.01/.02, circlip 932.01/.03
344	Bearing bracket lantern	with forcing screw 901.31, stud 902.04, hex. nut 920.04
360.01	Bearing cover	with gasket 400.01, socket head cap screw 914.01
382	Bearing carrier	with O-ring 412.02, grub screw 904.01, socket head cap screw 914.02, circlip 932.03
421.01/.02	Radial shaft seal ring	
451.01 <sup>1)</sup>	Stuffing box housing	with gasket 400.05, joint ring 411.16/.17/.18/.19/.26, drip plate 463.01, disc 550.01, stud 902.02, screwed plug 903.16/.17/.18/.19, hex. nut 920.02
452.01 <sup>1)</sup>	Gland cover	
454.01 <sup>1)</sup>	Stuffing box ring, split	
456.01 <sup>1)</sup>	Neck bush	
458.01 <sup>1)</sup>	Lantern ring, split	
461.01 <sup>1)</sup>	Gland packing	
502.01 <sup>4)</sup>	Casing wear ring	
507.01	Thrower	
524.01	Shaft protecting sleeve	with O-ring 412.06
906	Impeller screw	with O-ring 412.03
99-9	Set of sealing elements	with gasket 400.01/.02/.03/.04, joint ring 411.01/.02/.03/.10/.12/.13/.46, O-ring 412.02/.03/.05

1) if fitted

2) on pumps with mechanical seal

3) material variants GN, GN<sub>1</sub>, GC<sub>2</sub>, C<sub>2</sub> with packing

4) on 250-315 casing wear ring 502.01 instead of wear plate

Pumps on Bearing Brackets P 08sx, P 10ax and P 12sx

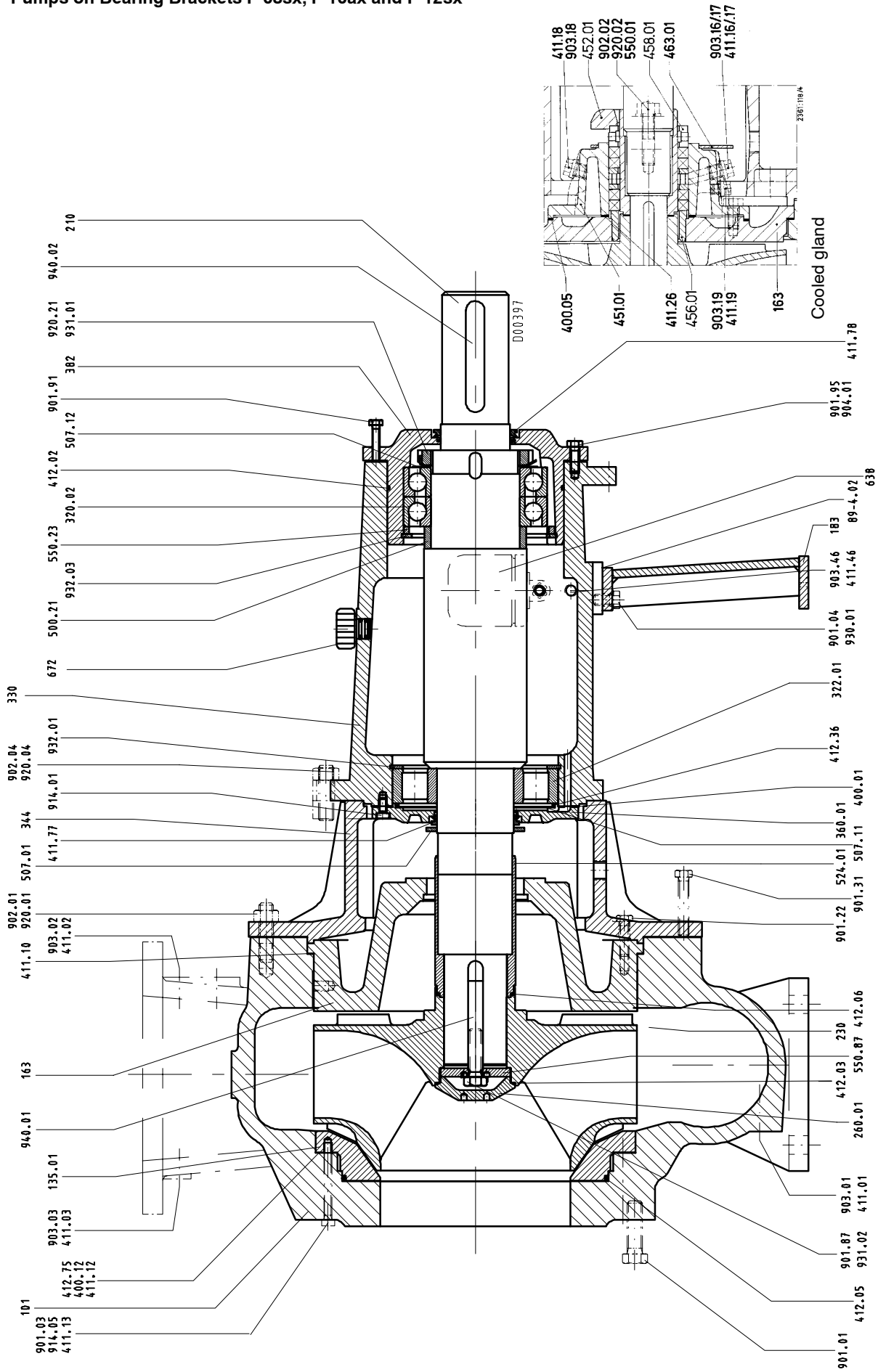

When ordering spare parts please always specify the type series/pump size, works No. (stamped on the name plate and on the suction nozzle flange), motor No. (serial No.), year of construction, quantity required, part No., description, material, medium handled, drawing No. and mode of dispatch.

<b>Part No.</b>	<b>Description</b>	<b>Scope of supply</b>
101	Pump casing	with joint ring 411.01 <sup>1)</sup> /.02 <sup>1)</sup> /.03 <sup>1)</sup> /.10, hex. head bolt 901.01, stud 902.01, screwed plug 903.01 <sup>1)</sup> /.02 <sup>1)</sup> /.03 <sup>1)</sup> , hex. nut 920.01
135.01 <sup>2)</sup>	Wear plate (suction-side)	with joint ring 411.12/.13, O-ring 412.05/.75, hex. head bolt 901.03, socket head cap screw 914.05
163 <sup>3)</sup>	Discharge cover (A-cover)	with hex. head bolt 901.22
163	Discharge cover (with integrally cast stuffing box housing)	with joint ring 411.16/.17, drip plate 463.01, disc 550.01, stud 902.02, screwed plug 903.16/.17, hex. nut 920.02
183	Support foot	with shim 89-4.02, hex. head bolt 901.04, spring washer 930.01
210	Shaft	with ring 500.21, keywayed nut 920.21, lockwasher 931.01, key 940.01/.02
230	Impeller	with O-ring 412.06
260.01	Impeller cap	with O-ring 412.03, disc 550.87, hex. head bolt 901.87, lockwasher 931.02
320.02	Angular contact ball bearing	
322.01	Cylindrical roller bearing	
330	Bearing bracket	
330	Bearing bracket (complete)	with bearing cover 360.01, gasket 400.01, joint ring 411.46/.77/.78, support disc 550.23, constant-level oiler 638, vent plug 672, hex. head bolt 901.91/.95, screwed plug 903.46, socket head cap screw 914.01, circlip 932.01/.03
344	Bearing bracket lantern	with hex. head bolt 901.22, forcing screw 901.31, stud 902.04, hex. nut 920.04
360.01	Bearing cover	with gasket 400.01, O-ring 412.36, disc 507.11, socket head cap screw 914.01
382	Bearing carrier	with O-ring 412.02, grub screw 904.01, hex. head bolt 901.95, circlip 932.03
411.77/.78	V-ring	
451.01 <sup>1)</sup>	Stuffing box housing	with gasket 400.05, joint ring 411.16/.17/.18/.19/.26, drip plate 463.01, disc 550.01, stud 902.02, screwed plug 903.16/.17/.18/.19, hex. nut 920.02
452.01 <sup>1)</sup>	Gland cover	
454.01 <sup>1)</sup>	Stuffing box ring, split	
456.01 <sup>1)</sup>	Neck bush	
458.01 <sup>1)</sup>	Lantern ring, split	
461.01 <sup>1)</sup>	Gland packing	
502.01	Casing wear ring <sup>2)</sup>	
507.01	Thrower	
524.01	Shaft protecting sleeve	with O-ring 412.06
99-9	Set of sealing elements	with gasket 400.01/.02/.12, joint ring 411.01/.02/.03/.12/.13/.46, O-ring 412.02/.03/.05/.06

1) if fitted

2) on 300-400 and 350-500 casing wear ring instead of wear plate

3) on pumps with mechanical seal

**Pumps on bearing bracket P 16 sx**

Suction cover  
part no. 162

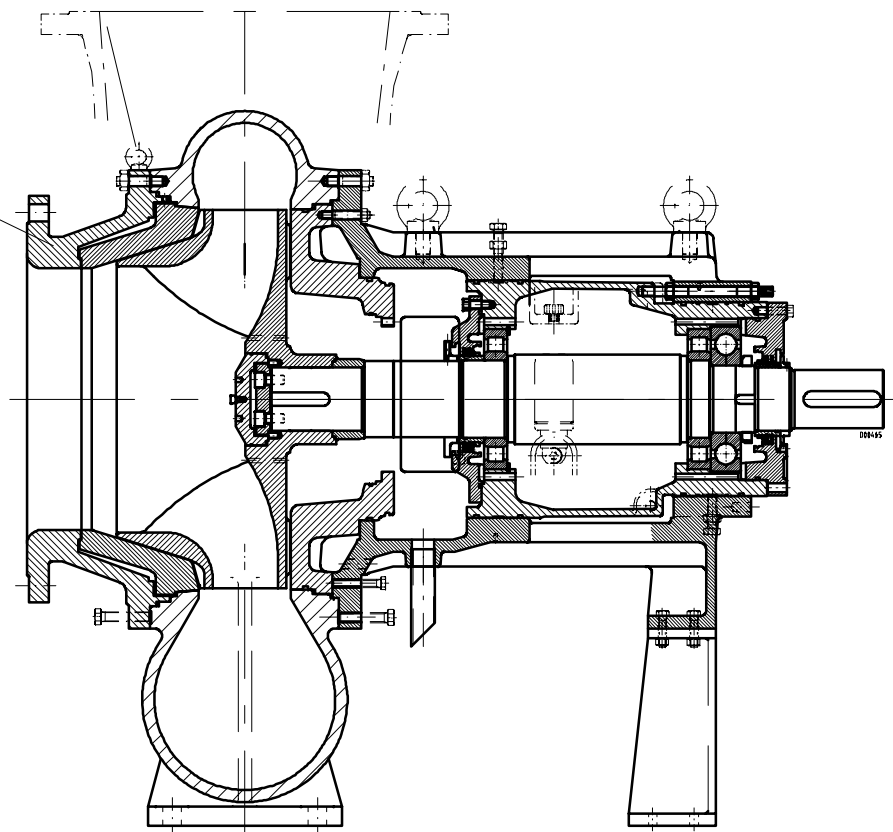

**Pumps on bearing bracket P 20 sx**

Suction cover  
part no. 162

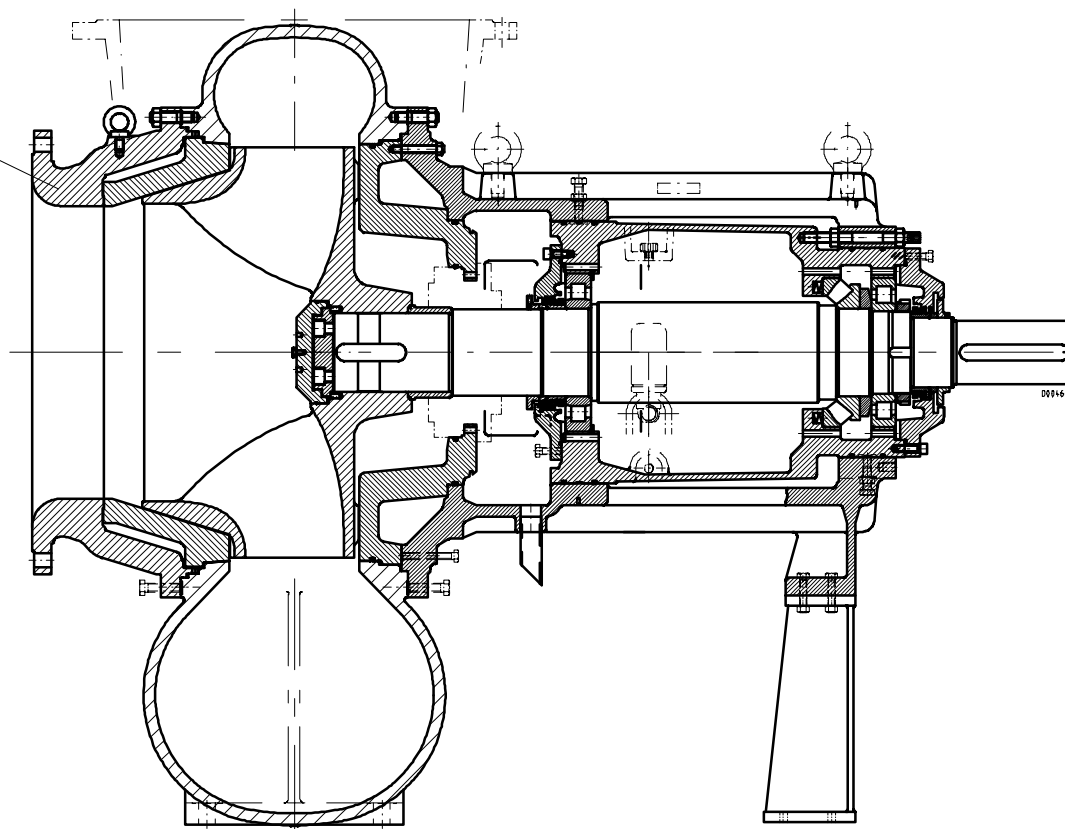

Subject to technical modifications

1.3.2001 XBS d/8